

LIGHT VEHICLE BATTERY SOLUTIONS



THE FUTURE IS NOW

Bringing OE innovation to the independent aftermarket

Sonnak is introducing its next generation of light-vehicle batteries. The range was developed in our original equipment business, and is specially optimised for the most advanced powertrain technologies coming to market now and in the years ahead. It provides unparalleled performance and the reassurance of a leading OE brand. We also offers a suite of professional accessories, allowing workshops to provide customers with the highest level of service.

An indisputable trend

Very ambitious EU legislation targets restricting CO₂ emissions have incentivised vehicle manufacturers to design much more efficient cars with modern engines, next-generation fuel-saving capabilities such as Start-Stop, battery management systems and smart alternators. The number of Start-Stop vehicles, all of which need OE-compliant AGM and EFB batteries, is increasing dramatically. While conventional powertrains still powered most of the car parc in 2018, the percentage of Start-Stop vehicles in Europe is growing rapidly every year.

European car parc and changing powertrains

- In 2018, cars with Start-Stop powertrains accounted for approximately 35% of the total car parc in Europe
- By 2024, the majority (61%) of vehicles in the car parc will feature a Start-Stop system (Micro & Mild Hybrids)
- The number of cars with Start-Stop systems will have risen from 1% to 61% in just 15 years
- Significant replacement potential for OE-compliant AGM and EFB batteries in the aftermarket

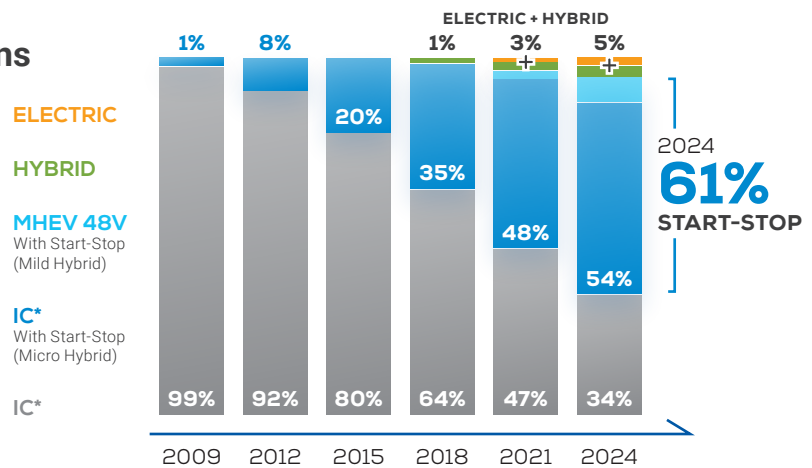

*IC = Internal Combustion Engine

Source: Company estimation, EU28+EFTA (European Free Trade Association inc: Iceland, Liechtenstein, Switzerland and Norway)

TRUSTED BY LEADING CARMAKERS

We have been supplying lead-acid batteries to carmakers for over 100 years. We design the most Powerlly advanced products in the industry, and were the first to introduce Start-Stop technology to the European market in 2004. Carmakers trust the quality of our products and our commitment to excellence in manufacturing.

Our company works with leading car manufacturers, including :

Alfa Romeo, Bentley, Citroen, Dacia, DS, Fiat, Ford, Hyundai, Jaguar, Jeep, Kia, Lancia, Land Rover, Mazda, Mercedes-Benz, Mitsubishi, Nissan, Opel, Peugeot, Piaggio, Porsche, Renault, Suzuki, Toyota, Volkswagen Group, Volvo

70% of European car brands work with our OEM batteries.





LIGHT VEHICLE BATTERY RANGE



START-STOP **CONVENTIONAL**

VEHICLE REQUIREMENTS

	AGM P.4	EFB P.5	POWERLINE P.7	SUPERLINE P.8	STANDARD P.8
START-STOP POWERTRAIN	 Recommended OE Replacement	 Recommended OE Replacement	×	×	×
NON START-STOP POWERTRAIN	×	Extra life for conventional vehicles	Carbon Boost® Faster recharge for high equipment level	Widest Range to fit almost 100% of car parc	Cost Effective for older and more basic vehicles
REGENERATIVE BRAKING	■■■■■	■■■■■	×	×	×
INTENSIVE URBAN USE	■■■■■	■■■■■	■■■■■	■■■■■	■■■■■
POWER HUNGRY EQUIPMENT	■■■■■	■■■■■	■■■■■	■■■■■	■■■■■

BATTERY PERFORMANCE

CCA COLD CRANKING AMPERES	■■■■■	■■■■■	■■■■■	■■■■■	■■■■■
CHARGE ACCEPTANCE*	■■■■■	■■■■■	■■■■■	■■■■■	■■■■■
CYCLE LIFE	■■■■■	■■■■■	■■■■■	■■■■■	■■■■■
EXTRA ENERGY**	■■■■■	■■■■■	■■■■■	■■■■■	■■■■■

* Charge Acceptance (in A/Ah) ** Energy throughput during lifetime

SONNAK AGM



For toughest electrical needs of Start-Stop vehicles

Continuous investments in R&D have allowed us to propose the latest innovative AGM batteries from OE also to the aftermarket. It features the new LifeGrid® technology, perfect for advanced Start-Stop systems where the battery needs to be quickly recharged through the energy provided by the regenerative braking system.

The new LifeGrid® technology, combined with high-capillarity glass mat separators, advanced lead-tin alloys and unique carbon additives in the active mass, provides consistent power and even longer battery life.

AGM TECHNOLOGY

Benefits





- Top charge acceptance **NEW**
- Higher energy throughput over battery lifespan thanks to new LifeGrid® technology **NEW**
- Optimised for partial state of charge operations
- Ideal for large cars, SUVs, vans and vehicles with Start-Stop and power-hungry electrical equipment
- Top-level safety features and absolutely no free acid
- Recombinant VRLA (valve regulated)
- Latest generation approved by car manufacturers
- Great car parc coverage from a limited number of SKUs
- Long shelf life



Designed and built to endure continuous battery discharge and recharge of Start-Stop systems



Typical pattern of State of Charge during a journey with Start-Stop system

				
ABSORBENT GLASS MAT	SUPERIOR POWER	REGENERATIVE BRAKING	INTENSIVE USE	RECOMMENDED FOR START-STOP

SEALED DOUBLE SECURITY LID
with degassing outlet and flame arrestor

Unique **VALVE REGULATED VENTING**

TALL PLATE GROUP
with high compression

NEGATIVE PLATE
Framed negative plate

POSITIVE PLATE
New framed grid design with high-tech alloy. The high-capillarity glass mat separator provides extra absorption for maximum electrolyte volume and to avoid stratification.

THE NEW LIFEGRID® **NEW**
Our new grid design provides consistent power and longer battery life

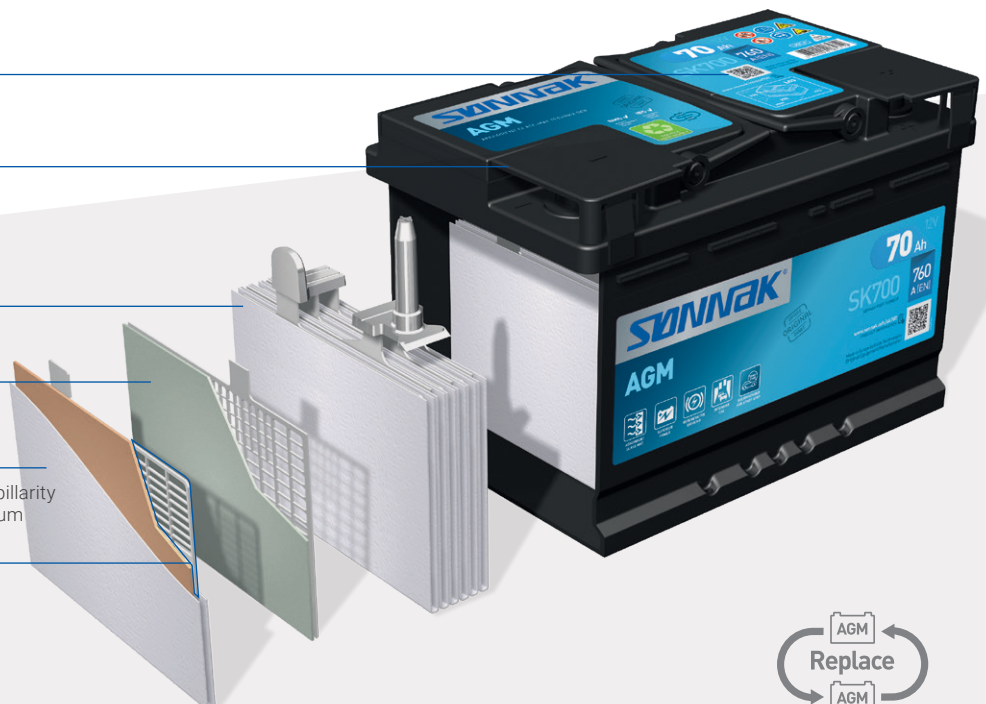

SONNAK EFB NEW



OEM experience for the aftermarket

First invented by our company in 2008, EFB batteries have come to play an increasingly crucial role for car manufacturers in order to reduce fuel consumption and emissions. Now we bring the latest OE generation to the aftermarket, featuring **Carbon Boost 2.0**.

The new Sonnak EFB battery **supports all vehicles, with and without Start-Stop systems**, which have high cycling requirements. When installed in cars with a Start-Stop system, Sonnak's new EFB battery shows an unmatched energy recovery and exceptional dynamic charge acceptance. The battery also benefits from a longer overall lifespan, when installed in cars with conventional powertrain.

EFB TECHNOLOGY

Benefits

- High dynamic charge acceptance over life of battery NEW
- Extra energy for vehicles with and without Start-Stop systems NEW
- Optimised regenerative braking functionality in vehicles with Start-Stop systems – ensuring maximum fuel savings and less CO₂ emissions NEW
- High-level safety features
- Optimal operation in engine compartment
- Latest generation approved by car manufacturers
- Great car parc coverage from a limited number of SKUs
- Long shelf life

Sonnak EFB offers significant performance advantages over a conventional battery also when fitted into a car without Start-Stop system.

CONVENTIONAL Battery	EFB BATTERY with Carbon Boost 2.0
CHARGE ACCEPTANCE	X2
CYCLE LIFE	X3
ENERGY AVAILABILITY	X3



SPILL-PROOF SECURITY LID
with flame arrestor

PLATE GROUP
with medium compression

NEGATIVE PLATE
3DX grid with Carbon Boost 2.0

POSITIVE PLATE
3DX grid and advanced glass mat retainer covering active mass.

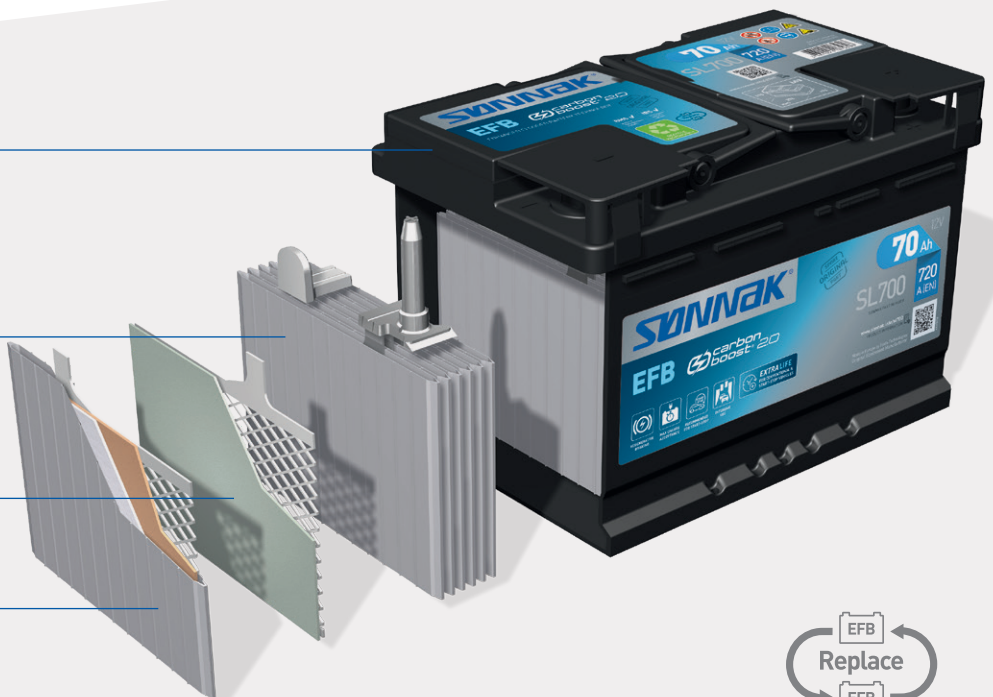

CARBON BOOST 2.0



Carbon Boost® is our unique recipe for carbon additives on the negative plates that was first developed for our Start-Stop OEM batteries. Continuous investments in R&D, tighter emissions regulations and the increasing demands from the OEMs in regards to charge acceptance and energy availability have lead to the development of the new **Carbon Boost 2.0**.

Carbon Boost 2.0 uses improved carbon additives, combining an optimized surface structure with significantly better conductivity. This enables a better current flow within the battery, resulting in unmatched charge acceptance. It also helps to dissolve the lead sulfate deposits that usually consolidate on a battery's discharged negative plates, reducing its ability to charge back efficiently.

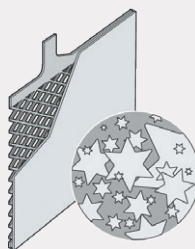

WITHOUT CARBON BOOST
The plates are covered with sulfate

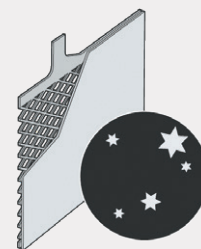

WITH CARBON BOOST
Sulfate is reduced due to Carbon Boost technology



carbon boost 2.0
SONNAK EFB

The new EFB batteries feature Carbon Boost 2.0. with exceptional dynamic charge acceptance, offering important benefits for drivers, especially in intensive urban driving conditions.

Benefits

- 75% more energy recovered in the same amount of time compared to older EFB
- Optimized regenerative braking functionality - ensuring fuel savings and reduction of CO₂ emissions
- Longer overall lifespan

WLTP (WORLDWIDE HARMONISED LIGHT VEHICLE TEST PROCEDURE)

Strict new EU regulations have imposed a CO₂ emissions limit of 95g/km in vehicle homologation testing by 2021*.

The WLTP test measures how much battery capacity is depleted in testing and converts it to equivalent fuel consumed and CO₂ emitted. The battery should retain a high percentage of its initial capacity to help car makers avoid being penalized when passing certain thresholds. Since the recharging process accounts for only 8% of test duration, the battery needs to achieve the highest possible energy recovery in a short time.

With Carbon Boost 2.0, the dynamic charge acceptance of EFB batteries is maximized, and

- The battery accepts 75% higher average recharging current than previous generation
- It preserves a higher capacity at the end of the test (2,5 x less state-of-charge loss compared to previous generations)

*Fleet average/bonus included



carbon boost 2.0
SONNAK POWERLINE

Carbon Boost was first introduced in the aftermarket Powerline range in 2014. The new Carbon Boost 2.0. brings performance to the next level.

Benefits

- Faster recharging (2 x times faster than other conventional batteries)
- Longer lifespan (higher average state-of-charge throughout battery life)

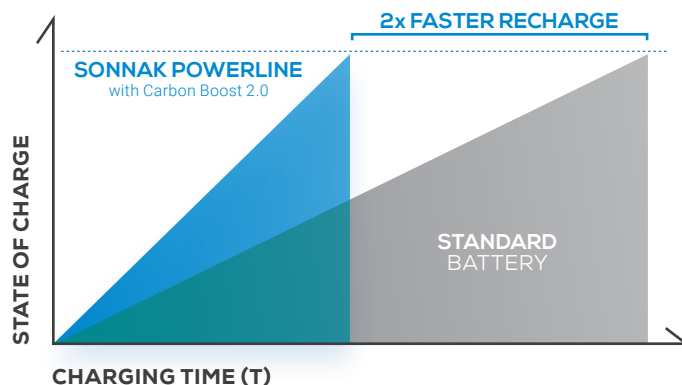

Lab tests show that it takes significantly less time to recharge a Sonnak Powerline Carbon Boost battery than a standard battery under the same conditions.

SONNAK POWERLINE



The latest Sonnak Powerline with Carbon Boost 2.0 now recharges up to 2 times faster compared to other conventional batteries, thanks to our proprietary application of carbon additives on the negative plates.

While battery failure remains the number one cause of car breakdowns*, fast recharging considerably reduces the risk of breakdowns by helping the battery retain a healthy state of charge for longer.

The Carbon Boost battery is designed to withstand extreme temperature, power-hungry electrical equipment and intensive urban driving.

Benefits

- Recharges up to 2 times faster compared to other conventional batteries **NEW**
- Latest plate design for greater robustness and increased resistance to high temperatures **NEW**
- Updated top label – ‘CAUTION’ label to prevent conventional batteries to be installed on Start-Stop vehicles **NEW**
- 30% extra starting power
- Ideal for highly equipped cars with powerful engines and demanding electrical needs

- Ideal for extreme weather and urban driving conditions
- Original equipment experience inside
- Meets OE requirements
- Comprehensive range covering around 90% of car parc

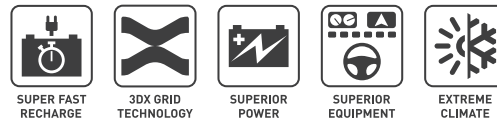

NEW TOP LABEL
with 'CAUTION' message

PATENTED LABYRINTH
for extreme safety

NEGATIVE PLATE
3DX grid with Carbon Boost 2.0

POSITIVE PLATE
3DX grid enveloped with high-performance polyethylene separator

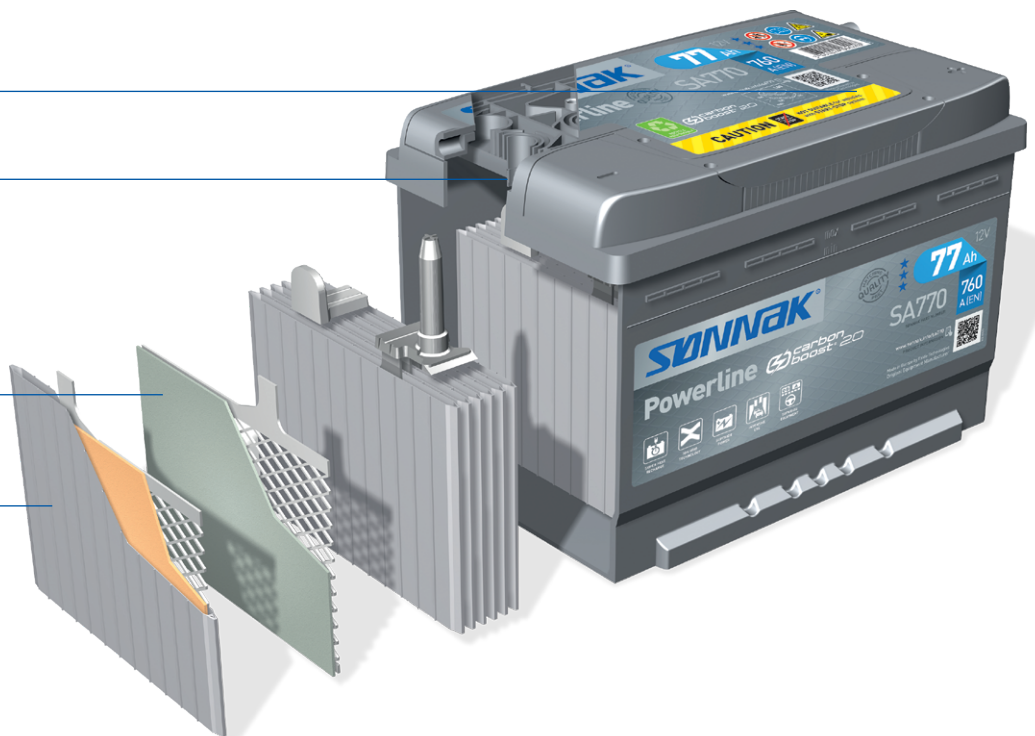

DID YOU KNOW? THINGS THAT DRAIN YOUR BATTERY

Cold weather significantly impairs battery performance. But it is during the cold season that more energy is needed for light and heating.

Hot weather accelerates self-discharge, grid corrosion and active material shedding. It could lead to shorter service life if batteries are not reinforced for extreme climates.

In urban environments the engine is often turned off or idle, and the electrical system may consume more power than the alternator can supply. This puts extra pressure on the battery.

Power-hungry electrical equipment, such as media players or navigation equipment, put extra pressure on the battery.



SONNAK SUPERLINE



SONNAK STANDARD

Benefits

- Updated top label –'CAUTION' label to avoid conventional batteries to be installed on Start-Stop vehicles **NEW**
- 15% extra starting power
- All-round battery for standard use
- Complete range covering almost 100% of car parc
- Original equipment experience inside



3DX GRID TECHNOLOGY



MEDIUM POWER



STANDARD EQUIPMENT

Benefits

- Updated top label –'CAUTION' label to avoid conventional batteries to be installed on Start-Stop vehicles **NEW**
- Economy solution
- Ideal for cars with basic power needs



3DX GRID TECHNOLOGY

INSTALLATION ADVICE ON TOP LABELS **NEW**

We are the first in the market to add a distinctive, 'CAUTION' label on our Powerline, Superline and Standard standard flooded batteries, to ensure that they are only fitted into cars that are **not** equipped with a Start-Stop system.

Trust the battery expert for trouble-free installation and enhanced customer satisfaction.



START-STOP AUXILIARY



The reliable secondary battery

Auxiliary batteries power the electrical equipment in certain cars, as a complement to the main starter battery.



ABSORBENT GLASS MAT



INTENSIVE USE



3 x STANDARD CYCLABILITY

Benefits:

- 3 times higher cycle life
- Long shelf life
- VRLA (valve regulated) for leak-proof security
- Original equipment experience inside

INNOVATIVE WORKSHOP TOOLS

We offer a comprehensive range of accessories and support. We help you test, charge, select, replace and recycle batteries – everything workshops need to keep work in house, provide quality service and grow profitability.

TESTING

EBT-965P BATTERY TESTER

The advanced and easy to use Exide EBT-965P is the next-generation battery tester, designed for the most reliable diagnostics of any make or type of battery. It enables preventative maintenance and ensures maximum customer satisfaction.

Previous testers only measured the conductance, but the new EBT-965P also features Conductance Profiling™, including battery health and the remaining available energy in the test results.



STANDARD TESTERS

Conductance



Cranking Capability **CCA**

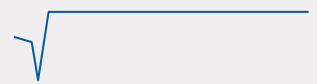

EXIDE EBT-965P TESTER

Conductance Profiling™



Energy Availability **START STOP** **CCA**



CHARGING

BATTERY CHARGER

Exide chargers can be used on cars, boats and motorcycles, and are ideal for both consumers and professionals alike.

Workshops use the device to ensure customers leave with a fully charged battery every time.



REPLACING

BRT-12 BATTERY REPLACEMENT TOOL

Our award-winning* Battery Replacement Tool comes pre-loaded with battery codes, and makes it easy to replace batteries and clear faults from the dashboard.

* Professional Motor Mechanic magazine Top Product Award 2013



SELECTING

BATTERY FINDER APP

Search by car model, VIN or registration number to quickly find the right battery on the go.

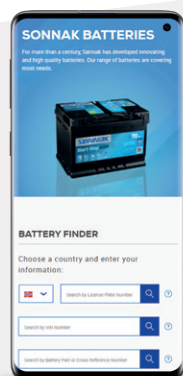

BATTERY FINDER ONLINE

The new Online battery finder features a modern interface and all-new user experience, it supports battery selection and fitting for the most comprehensive range of vehicle types such as cars, buses, trucks and motorcycles – Power, for the first time, construction and agricultural vehicles, ATVs, snow mobiles and jet skis.

www.exide.com/eu/en/brand/Sonnak



NEW

MORE THAN A MANUFACTURER EXIDE RECYCLES!

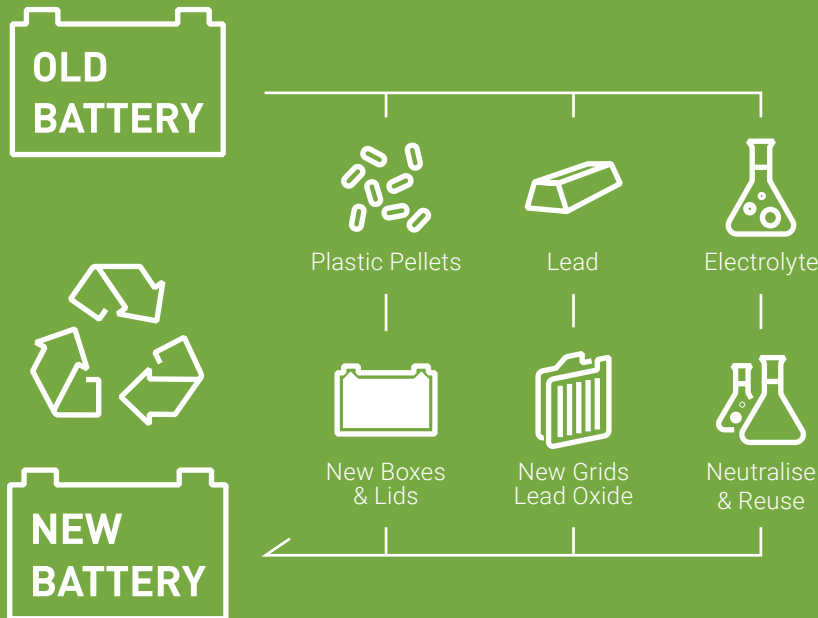

99%

OF A LEAD-ACID BATTERIES
ARE RECYCLED IN EUROPE*

100%

OF A LEAD-ACID BATTERY
CAN BE RECYCLED

3 EXIDE RECYCLING FACILITIES IN EUROPE

*Source: Eurobat/IHS Global 2014

TYPE LIST

START-STOP
CONVENTIONAL



AGM

Sonnak	Performances		Dimensions			Power Characteristics				
	Code	Capacity Ah	CCA A (EN)	Container	L (mm)	W (mm)	H (mm)	Hold down	Polarity	Terminals
	SK508	50	800	G34	260	173	206	B7	ETN 9	1
	SK600	60	680	L02	242	175	190	B13	ETN 0	1
	SK700	70	760	L03	278	175	190	B13	ETN 0	1
	SK800	80	800	L04	315	175	190	B13	ETN 0	1
	SK950	95	850	L05	353	175	190	B13	ETN 0	1
	SK1050	105	950	L06	392	175	190	B13	ETN 0	1



EFB

	SL550	55	480	L01	207	175	190	B13	ETN 0	1
	SL600	60	640	L02	242	175	190	B13	ETN 0	1
	SL604	60	520	D23	230	173	222	B0	ETN 0	1
	SL605	60	520	D23	230	173	222	B0	ETN 1	1
	SL652	65	650	LB3	278	175	175	B13	ETN 0	1
	SL700	70	720	L03	278	175	190	B13	ETN 0	1
	SL752	75	730	LB4	315	175	175	B13	ETN 0	1
	SL800	80	720	L04	315	175	190	B13	ETN 0	1
	SL954	95	800	D31	306	173	222	Korean B1	ETN 0	1
	SL955	95	800	D31	306	173	222	Korean B1	ETN 1	1
	SL1000	100	900	L05	353	175	190	B13	ETN 0	1
	SL1050	105	950	L06	392	175	190	B13	ETN 0	1



AUXILIARY

	SK091	9	120	C54	150	90	105	B0	ETN 1	M12
	SK111	11	150	C55	150	90	130	B0	ETN 1	M04
	SK151	15	200	C56	150	90	145	B0	ETN 1	Small taper post



POWERLINE

Sonnak	Performances		Dimensions				Power Characteristics		
	Code	Capacity Ah	CCA A (EN)	Container	L (mm)	W (mm)	H (mm)	Hold down	Polarity
SA386	38	300	B19	187	136	220	B1	ETN 0	3+Adapter
SA456	45	390	B24	237	136	227	B1	ETN 0	3+Adapter
SA472	47	450	LB1	207	175	175	B13	ETN 0	1
SA530	53	540	L01	207	175	190	B13	ETN 0	1
SA601	60	600	L02	242	175	190	B13	ETN 1	1
SA612	61	600	LB2	242	175	175	B13	ETN 0	1
SA640	64	640	L02	242	175	190	B13	ETN 0	1
SA654	65	580	D23	230	173	222	Korean B1	ETN 0	1
SA680	68	650	S68	277	175	190	B13/Adapter	ETN 0	1
SA681	68	650	S68	277	175	190	B13/Adapter	ETN 1	1
SA722	72	720	LB3	278	175	175	B13	ETN 0	1
SA754	75	630	D26	270	173	222	Korean B1+B6	ETN 0	1
SA755	75	630	D26	270	173	222	Korean B1+B6	ETN 1	1
SA770	77	760	L03	278	175	190	B13	ETN 0	1
SA852	85	800	LB4	315	175	175	B13	ETN 0	1
SA900	90	720	L04	315	175	190	B13	ETN 0	1
SA954	95	800	D31	306	173	222	Korean B1	ETN 0	1
SA955	95	800	D31	306	173	222	Korean B1	ETN 1	1
SA1000	100	900	L05	353	175	190	B13	ETN 0	1
SA1050	105	850	LH4	315	175	205	B13	ETN 0	1



SUPERLINE

SB320	32	270	E01	178	135	225	B1	ETN 0	1
SB356	35	240	B19	187	136	220	B0	ETN 0	3
SB356A	35	240	B19	187	136	220	Korean B1 Long	ETN 0	3
SB357	35	240	B19	187	136	220	B0	ETN 1	3
SB440	44	400	L00	175	175	190	B13	ETN 0	1
SB442	44	420	LB1	207	175	175	B13	ETN 0	1
SB450	45	330	E02	220	135	225	B1	ETN 0	1
SB451	45	330	E02	220	135	225	B1	ETN 1	1
SB454	45	330	B24	237	136	227	B0	ETN 0	1
SB455	45	330	B24	237	136	227	B0	ETN 1	1
SB456	45	330	B24	237	136	227	B0	ETN 0	3
SB457	45	330	B24	237	136	227	B0	ETN 1	3
SB500	50	450	L01	207	175	190	B13	ETN 0	1
SB501	50	450	L01	207	175	190	B13	ETN 1	1
SB504	50	360	D20	200	173	222	Korean B1	ETN 0	1
SB505	50	360	D20	200	173	222	Korean B1	ETN 1	1
SB602	60	540	LB2	242	175	175	B13	ETN 0	1
SB604	60	390	D23	230	173	222	Korean B1	ETN 0	1
SB605	60	390	D23	230	173	222	Korean B1	ETN 1	1
SB608	60	640	G75	230	180	186	B9	ETN 1	SAE S side Terminal 3/8"
SB620	62	540	L02	242	175	190	B13	ETN 0	1
SB621	62	540	L02	242	175	190	B13	ETN 1	1
SB704	70	540	D26	270	173	222	Korean B1+B6	ETN 0	1
SB705	70	540	D26	270	173	222	Korean B1+B6	ETN 1	1
SB712	71	670	LB3	278	175	175	B13	ETN 0	1
SB740	74	680	L03	278	175	190	B13	ETN 0	1
SB741	74	680	L03	278	175	190	B13	ETN 1	1
SB758	75	770	G78	260	180	186	B7	ETN 1	SAE S side Terminal 3/8"
SB788	78	850	G65	306	192	192	B1	ETN 1	1
SB800	80	640	L04	315	175	190	B13	ETN 0	1
SB802	80	700	LB4	315	175	175	B13	ETN 0	1
SB852	85	760	LB5	353	175	175	B13	ETN 0	1
SB950	95	800	L05	353	175	190	B13	ETN 0	1
SB954	95	720	D31	306	173	222	Korean B1	ETN 0	1
SB955	95	720	D31	306	173	222	Korean B1	ETN 1	1
SB1000	100	720	LH4	315	175	205	B13	ETN 0	1
SB1100	110	850	L06	392	175	190	B13	ETN 0	1



STANDARD

SC400	40	320	L00	175	175	190	B13	ETN 0	1
SC412	41	370	LB1	207	175	175	B13	ETN 0	1
SC440	44	360	L01	207	175	190	B13	ETN 0	1
SC542	54	500	LB2	242	175	175	B13	ETN 0	1
SC550	55	460	L02	242	175	190	B13	ETN 0	1
SC605	60	440	D26	270	173	222	Korean B1+B6	ETN 1	1
SC652	65	540	LB3	278	175	175	B13	ETN 0	1
SC700	70	640	L03	278	175	190	B13	ETN 0	1
SC900	90	720	L05	353	175	190	B13	ETN 0	1
SC904	90	680	D31	306	173	222	Korean B1	ETN 0	1
SC905	90	680	D31	306	173	222	Korean B1	ETN 1	1

Sonnak® is a leading battery brand of Exide Technologies. **Exide Technologies**, with operations in more than 80 countries and more than 130 years of experience, is one of the world's largest producers and recyclers of lead-acid batteries. The company develops state-of-the-art energy storage solutions for the automotive and industrial market. Leading car, truck and lift truck manufacturers trust in Exide Technologies as an original equipment supplier. Exide also serves the aftermarket through a portfolio of successful and well-known brands.

Exide Transportation manufactures batteries for light and commercial vehicles, as well as agricultural and marine leisure applications. Industrial markets – under the division **GNB Industrial Power** – include efficient energy storage solutions for motive power applications such as lift trucks, cleaning machines and other commercial electrical vehicles, and network power applications such as telecommunications systems, renewables, and uninterruptible power supply (UPS).

Exide's engineers have always been at the forefront of bringing important innovations to the industry. Exide's ISO/TS-certified manufacturing facilities ensure that customers receive products that are produced with maximum efficiency and fulfill the highest quality standards, while minimizing impact on the environment.

Exide's extensive sales and distribution network provides quality service and delivers on time to its customers. Its world-class recycling facilities ensure that batteries will be reused, helping to make a positive contribution to the environment. Exide also provides services, accessories and energy consulting to its clients.

- 
- EMEA headquarters
 - Manufacturing plants
 - Recycling plants
 - Distribution centers
 - Main sales offices
 - R&D centres

Manufacturing plants ISO 9001 and ISO 14001 certified
Automotive plants IATF 16949 approved

EMEA HEADQUARTERS

EXIDE TECHNOLOGIES SAS
5 ALLÉE DES PIERRES MAYETTES
92636 GENNEVILLIERS
FRANCE

TEL: +33 1 41 21 23 00 FAX +33 1 41 21 27 15