

Käynnistysakkujen tekniset kaaviot

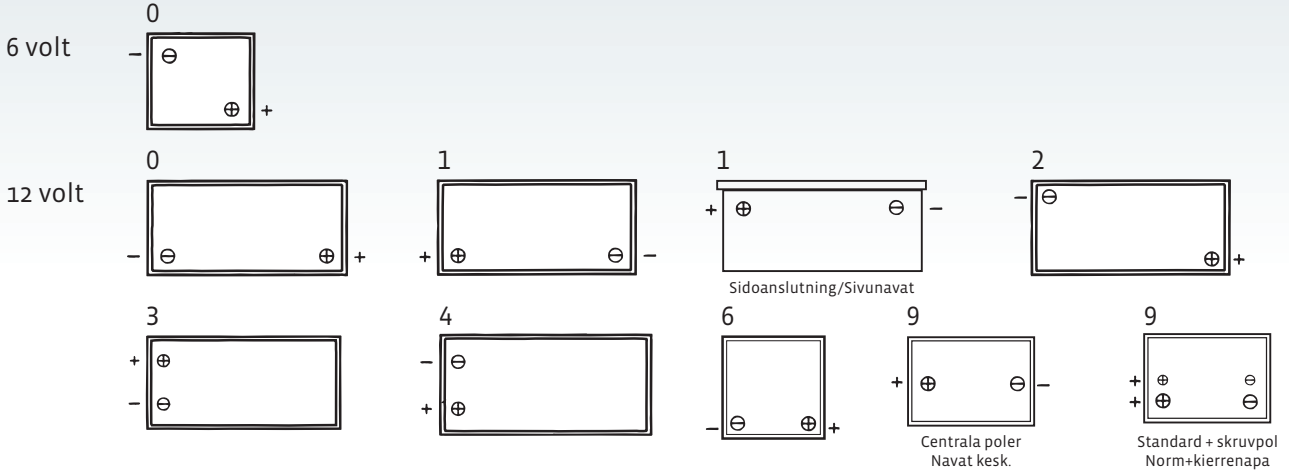

Henkilö- ja kuorma-autot, vapaa-ajanakut

KENNOJEN SIJOITUS



ULOSOTTONAVAT

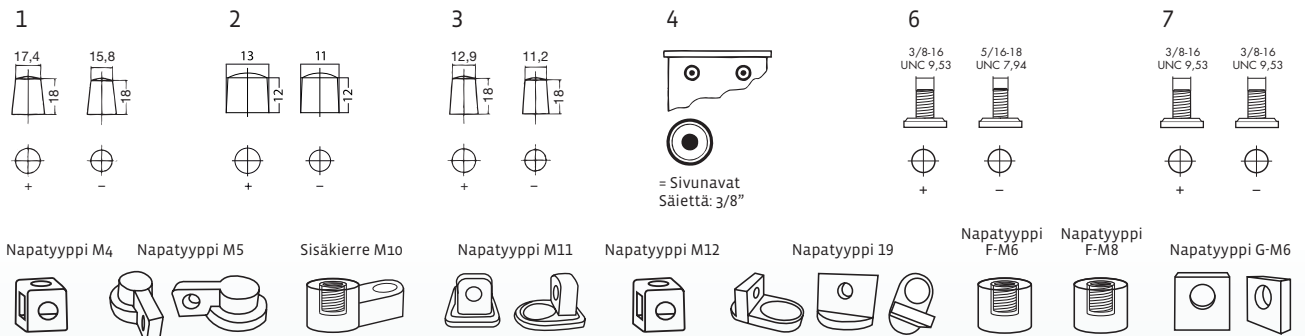

POHJAKIINNITYS

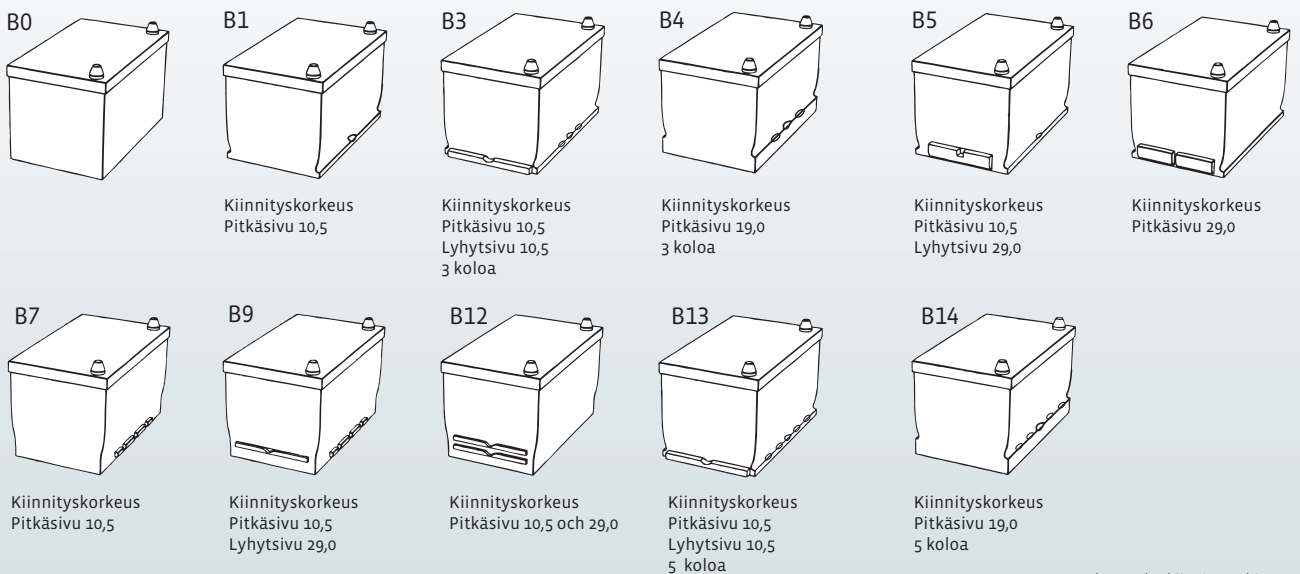

Notches: Kolot kiinnityspohjassa